

## BODY DIMENSIONS

### General Information

#### 1. BASIC DIMENSIONS

(a) There are two types of dimensions in the diagram.  
(Three-dimensional distance)

- Straight-line distance between the centers of two measuring points.

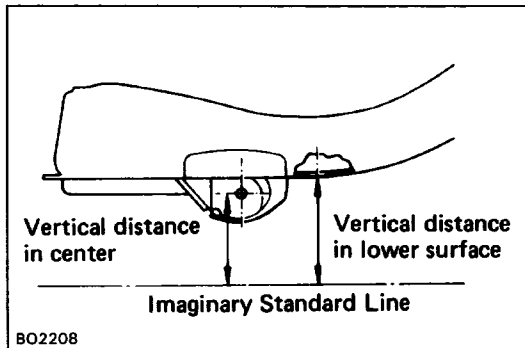

(Two-dimensional distance)

- Horizontal distance in forward/rearward between the centers of two measuring points.

- The height from an imaginary standard line.

(b) Incases in which only one dimension is given, left and right are symmetrical.

(c) The dimensions in the following drawing indicate actual distance. Therefore, please use the dimensions as a reference.

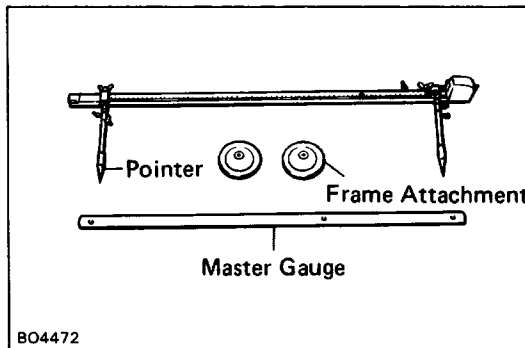

#### 2. MEASURING

(a) Basically, all measurements are to be done tracking gauge. For portions where it is not possible to use a tracking gauge, a tape measure should be used.

(b) Use only tracking gauge that has no looseness in the body, measuring plate, or pointers.

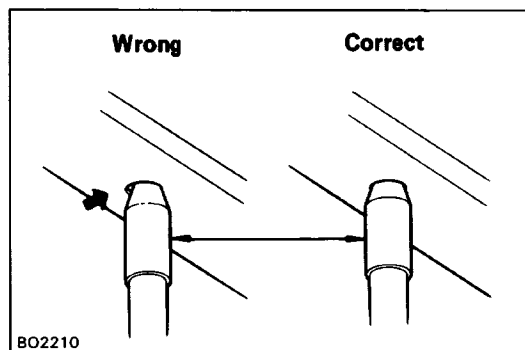

#### HINT:

1. The height of the left and right pointers must be equal.
  2. Always calibrate the tracking gauge before measuring or after adjusting the pointer height.
  3. Take care not to drop the tracking gauge or otherwise shock it.
  4. Confirm that the pointers are securely in the holes.
- (c) When using a tape measure, avoid twists and bends in the tape.

# Body Dimensions

**OVERHEAD VIEW**  
 (Three-Dimensional Distance)  
**REGULAR CAB**

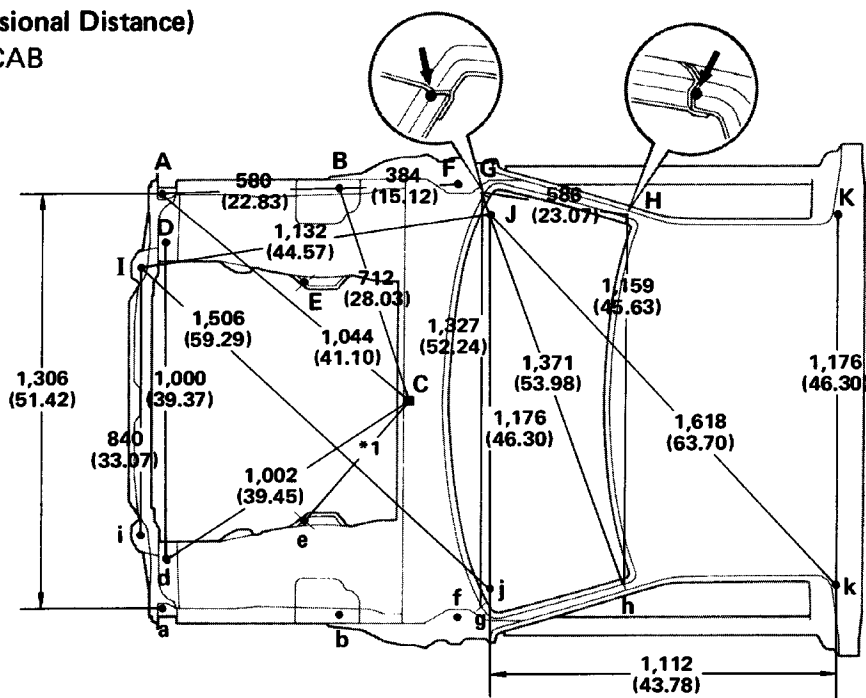

\*1: 2WD 655 (25.79)  
 4WD 688 (27.09)

**XTRA CAB**

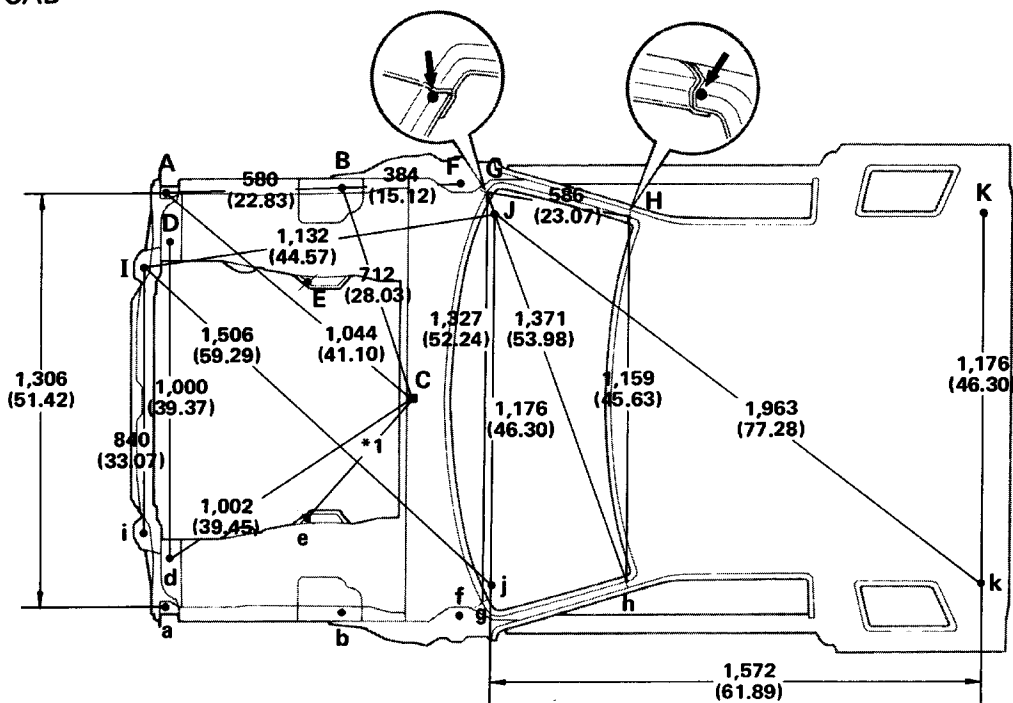

mm (in.)

BO3601  
 BO3602

Symbol	Name	Hole dia.	Symbol	Name	Hole dia.
A,a	Front fender installation nut	8 (0.31)	G,g	Front body pillar/Cowl panel adjoining portion	—
B,b	Front fender installation nut	8 (0.31)	H,h	Roof panel/Front body pillar adjoining portion	—
C	Cowl ventilation louver installation nut	7.5 x 7.5 (0.295 x 0.295)	I,i	Cab mounting hole	RH 11 (0.43) LH 15 x 12 (0.59 x 0.47)
D,d	Fender apron standard hole	25 (0.98)	J,j	Cab mounting hole	22 (0.87)
E,e	Fender apron seal installation hole	8 (0.31)	K,k	Cab mounting hole	RH 22 (0.87) LH 23 x 12 (0.91 x 0.47)
F,f	Cowl top panel standard hole	10 (0.39)			

**FRONT VIEW**  
**(Three-Dimensional Distance)**  
**ALL MODELS**

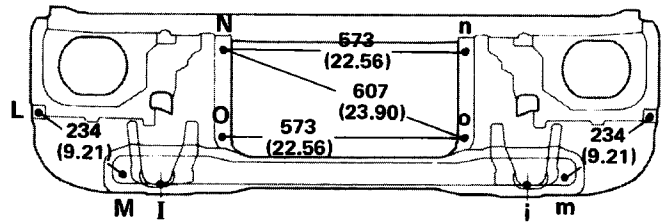

**REAR VIEW**  
**(Three-Dimensional Distance)**  
**ALL MODELS**

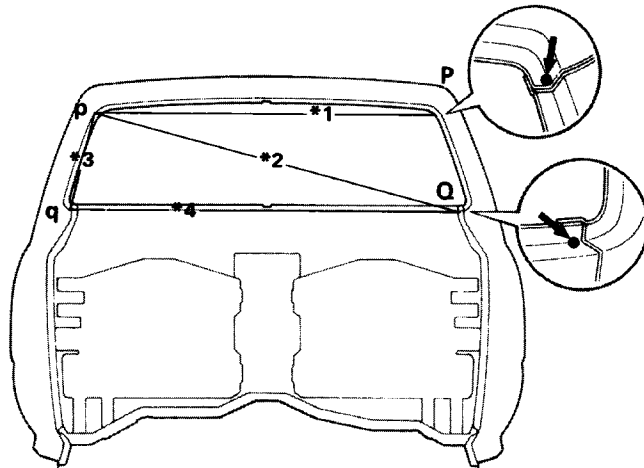

**SIDE VIEW**  
**(Three-Dimensional Distance)**  
**ALL MODELS**

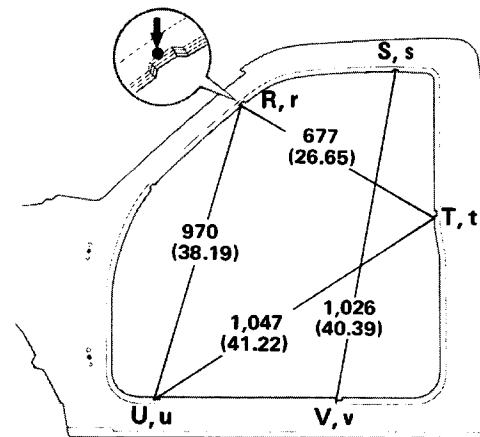

- \*1: Regular Cab 1,110 (43.70)  
Xtra Cab 1,104 (43.46)
- \*2: Regular Cab 1,216 (47.87)  
Xtra Cab 1,231 (48.46)
- \*3: Regular Cab 305 (12.01)  
Xtra Cab 346 (13.62)
- \*4: Regular Cab 1,248 (49.13)  
Xtra Cab 1,264 (49.76)

**NOTE:** For symbol, capital letters indicate right side of vehicle, small letters indicate left side of vehicle.

BO3603  
 BO3604 BO3605

mm (in.)

Symbol	Name	Hole dia.	Symbol	Name	Hole dia.
I, i	Cab mounting hole RH 11 (0.43) LH 15 x 12 (0.59 x 0.47)		Q, q	Back panel/Quarter panel adjoining portion	—
L, l	Front fender installation nut	7 (0.28)	R, r	Front body pillar assembly mark	—
M, m	Front crossmember standard hole	13 (0.51)	S, s	Roof side rail assembly mark	—
N, n	Radiator installation nut	9 (0.35)	T, t	Quarter panel assembly mark	—
O, o	Radiator installation nut	9 (0.35)	U, u	Rocker panel assembly mark	—
P, p	Roof panel/Quarter panel adjoining portion	—	V, v	Rocker panel assembly mark	—
			—	—	—

# Frame Dimensions

## 2WD Regular Cab: Short Wheel Base Models

(Three-Dimensional Distance)

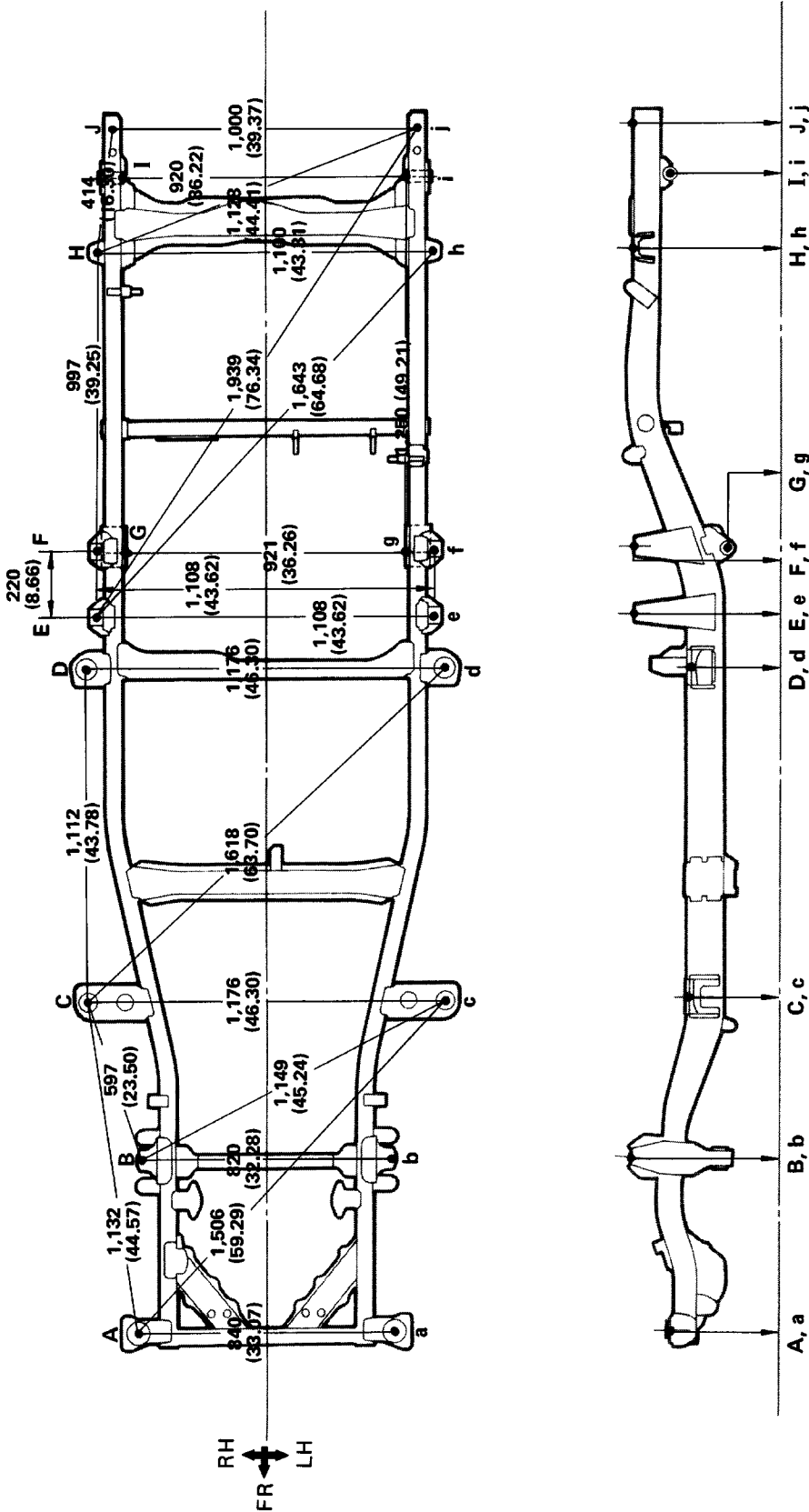

Symbol	Name	Hole dia.	Symbol	Name	Hole dia.
A,a	Cab mounting hole	24 (0.94)	F,f	Rear body mounting hole	17 (0.67)
B,b	Shock absorber installation hole	16 (0.63)	G,g	Rear spring front hanger hole — inner	14.5 (0.571)
C,c	Cab mounting hole	60 (2.36)	H,h	Rear body mounting hole	17 (0.67)
D,d	Cab mounting hole	70 (2.76)	I,i	Rear spring rear hanger hole — inner	30.35 (1.1949)
E,e	Rear body mounting hole	17 (0.67)	J,j	Rear body mounting hole	18 x 21 (0.71 x 0.83)

## 2WD Regular Cab: Short Wheel Base Models

(Two-Dimensional Distance)

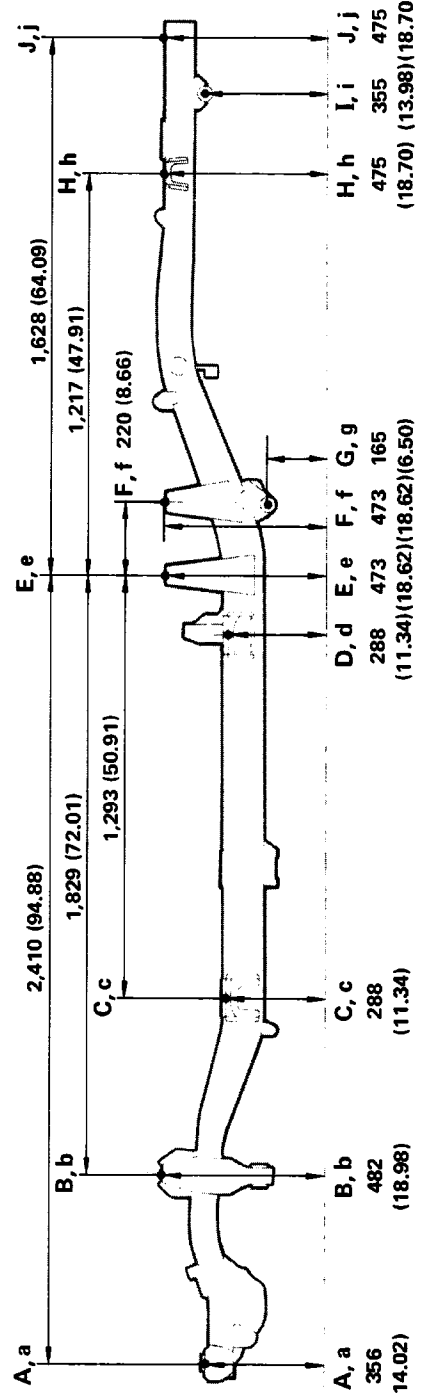
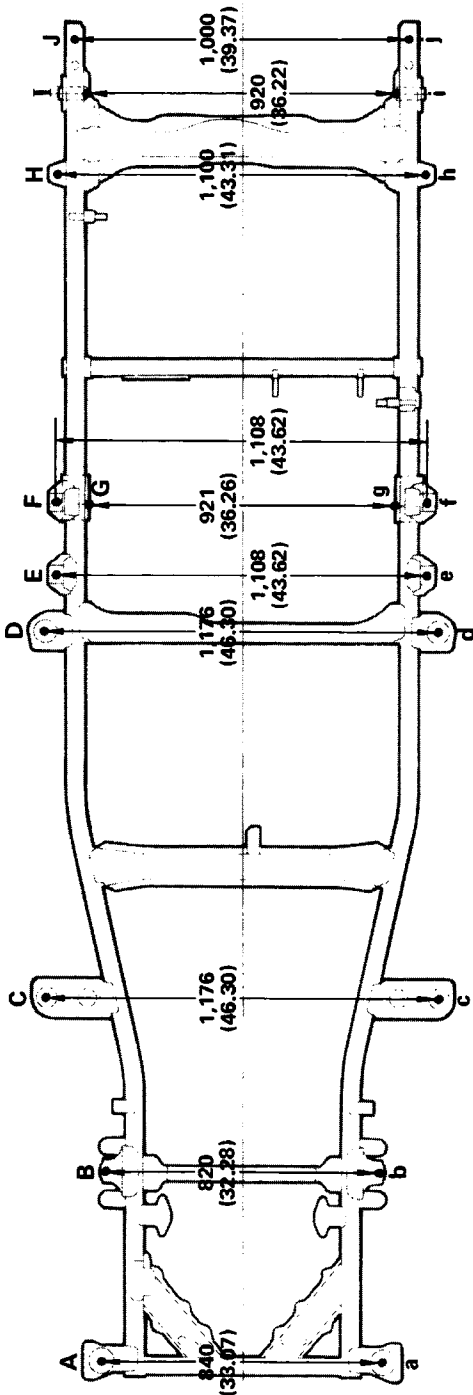

Imaginary Standard Line

Wheel base: 2,615 (102.95)

Symbol	Name	Hole dia.	Symbol	Name	Hole dia.
A,a	Cab mounting hole	24 (0.94)	F,f	Rear body mounting hole	17 (0.67)
B,b	Shock absorber installation hole	16 (0.63)	G,g	Rear spring front hanger hole - inner	14.5 (0.571)
C,c	Cab mounting hole	60 (2.36)	H,h	Rear body mounting hole	17 (0.67)
D,d	Cab mounting hole	70 (2.76)	I,i	Rear spring rear hanger hole - inner	30.35 (1.1949)
E,e	Rear body mounting hole	17 (0.67)	J,j	Rear body mounting hole	18 x 21 (0.71 x 0.83)

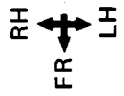

## 2WD Regular Cab: Long Wheel Base Models

(Three-Dimensional Distance)

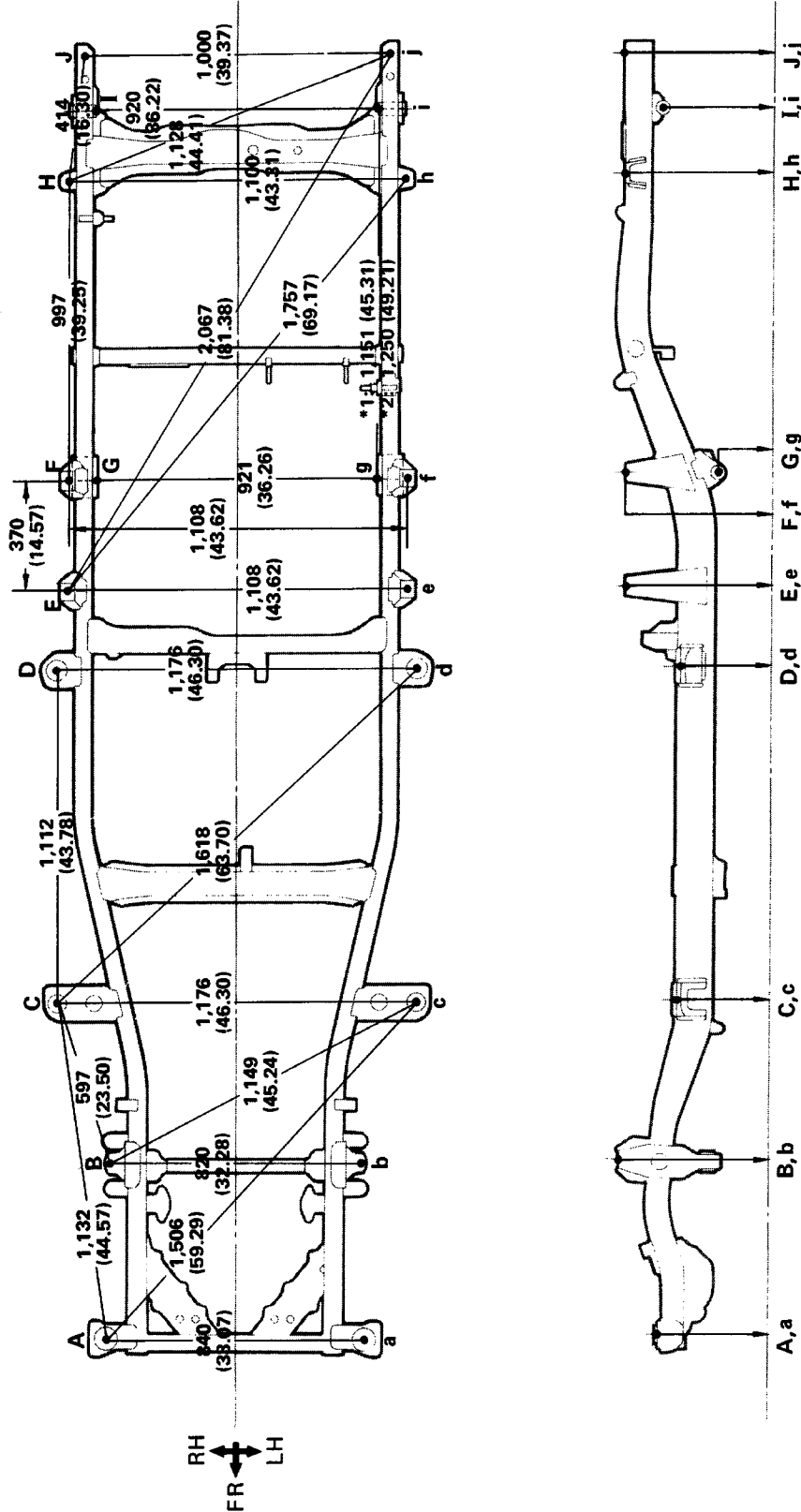

\*1: Loading Capacity 1.0 ton, and Cab and Chassis Models  
 \*2: Loading Capacity 0.5 ton Models

Symbol	Name	Hole dia.	Symbol	Name	Hole dia.
A,a	Cab mounting hole	24 (0.94)	G,g	Rear spring front hanger hole - inner	14.5 (0.571)
B,b	Shock absorber installation hole	16 (0.63)	H,h	Rear body mounting hole	17 (0.67)
C,c	Cab mounting hole	60 (2.36)	I,i	Rear spring rear hanger hole - inner	30.35 (1.1949)
D,d	Cab mounting hole	70 (2.76)	J,j	Rear body mounting hole	18 x 21 (0.71 x 0.83)
E,e	Rear body mounting hole	17 (0.67)	-	-	-
F,f	Rear body mounting hole	17 (0.67)	-	-	-

mm (in.)

## 2WD Regular Cab: Long Wheel Base Models

(Two-Dimensional Distance)

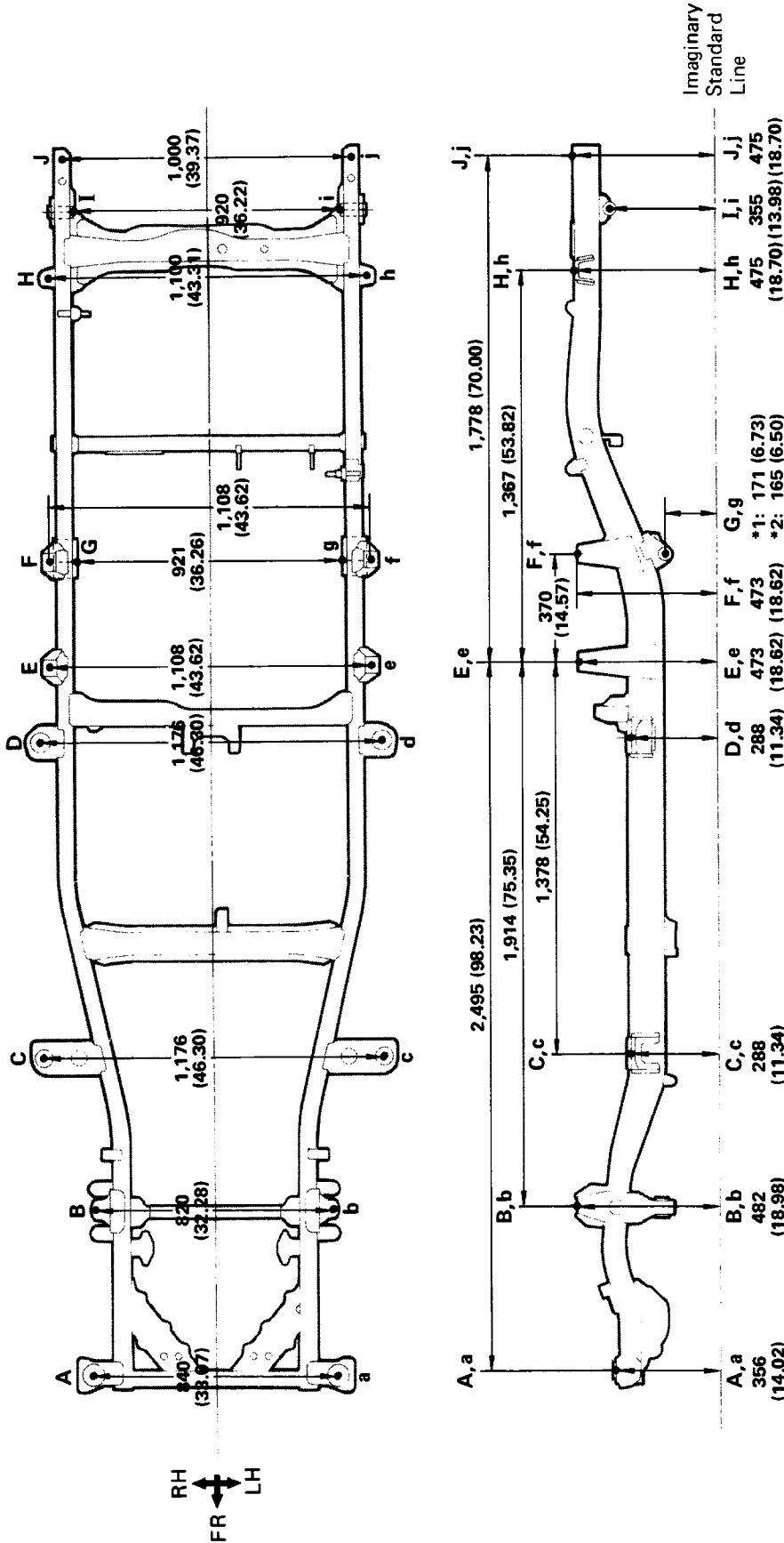

\*1: Loading Capacity: 1.0 ton, and Cab and Chassis Models  
 \*2: Loading Capacity: 0.5 ton Models

Wheel Base: 2,850 (112.20)

Symbol	Name	Hole dia.	Symbol	Name	Hole dia.
A,a	Cab mounting hole	24 (0.94)	G,g	Rear spring front hanger hole - inner	*1 14.6 (0.575) *2 14.5 (0.571)
B,b	Shock absorber installation hole	16 (0.63)	H,h	Rear body mounting hole	17 (0.67)
C,c	Cab mounting hole	60 (2.36)	I,i	Rear spring rear hanger hole - inner	30.35 (1.1949)
D,d	Cab mounting hole	70 (2.76)	J,j	Rear body mounting hole	18 x 21 (0.71 x 0.83)
E,e	Rear body mounting hole	17 (0.67)			
F,f	Rear body mounting hole	17 (0.67)			

## 2WD Regular Cab: Super Long Wheel Base Models

(Three-Dimensional Distance)

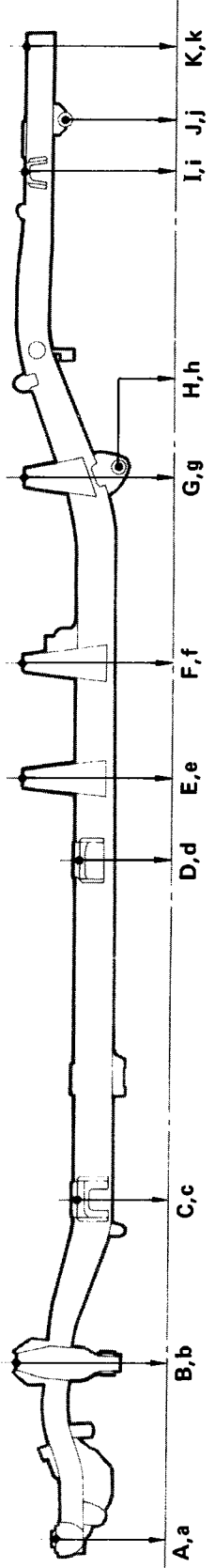
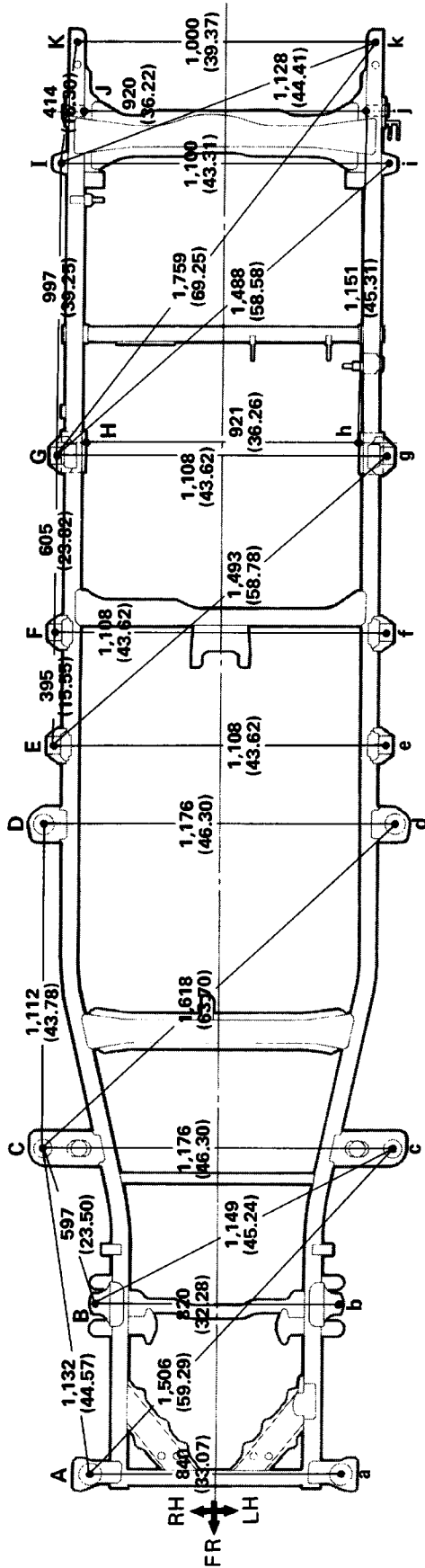

Symbol	Name	Hole dia.	Symbol	Name	Hole dia.
A,a	Cab mounting hole	24 (0.94)	G,g	Rear body mounting hole	17 (0.67)
B,b	Shock absorber installation hole	16 (0.63)	H,h	Rear spring front hanger hole - inner	14.6 (0.575)
C,c	Cab mounting hole	60 (2.36)	I,i	Rear body mounting hole	17 (0.67)
D,d	Cab mounting hole	70 (2.76)	J,j	Rear spring rear hanger hole - inner	30.35 (1.1949)
E,e	Rear body mounting hole	17 (0.67)	K,k	Rear body mounting hole	18 x 21 (0.71 x 0.83)
F,f	Rear body mounting hole	17 (0.67)			



## 2WD Regular Cab: Super Long Wheel Base Models

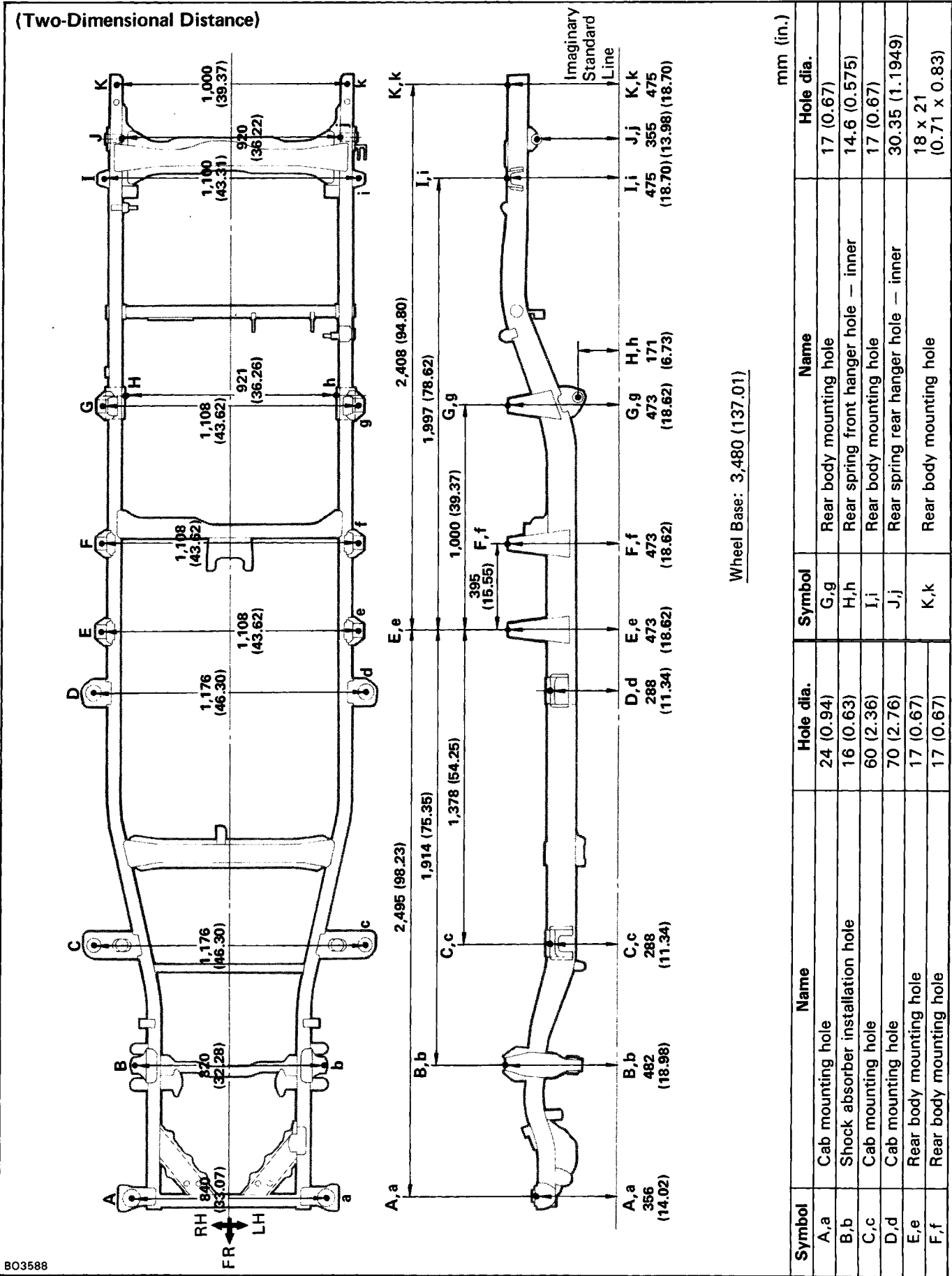



### 2WD Xtra Cab Models

(Two-Dimensional Distance)

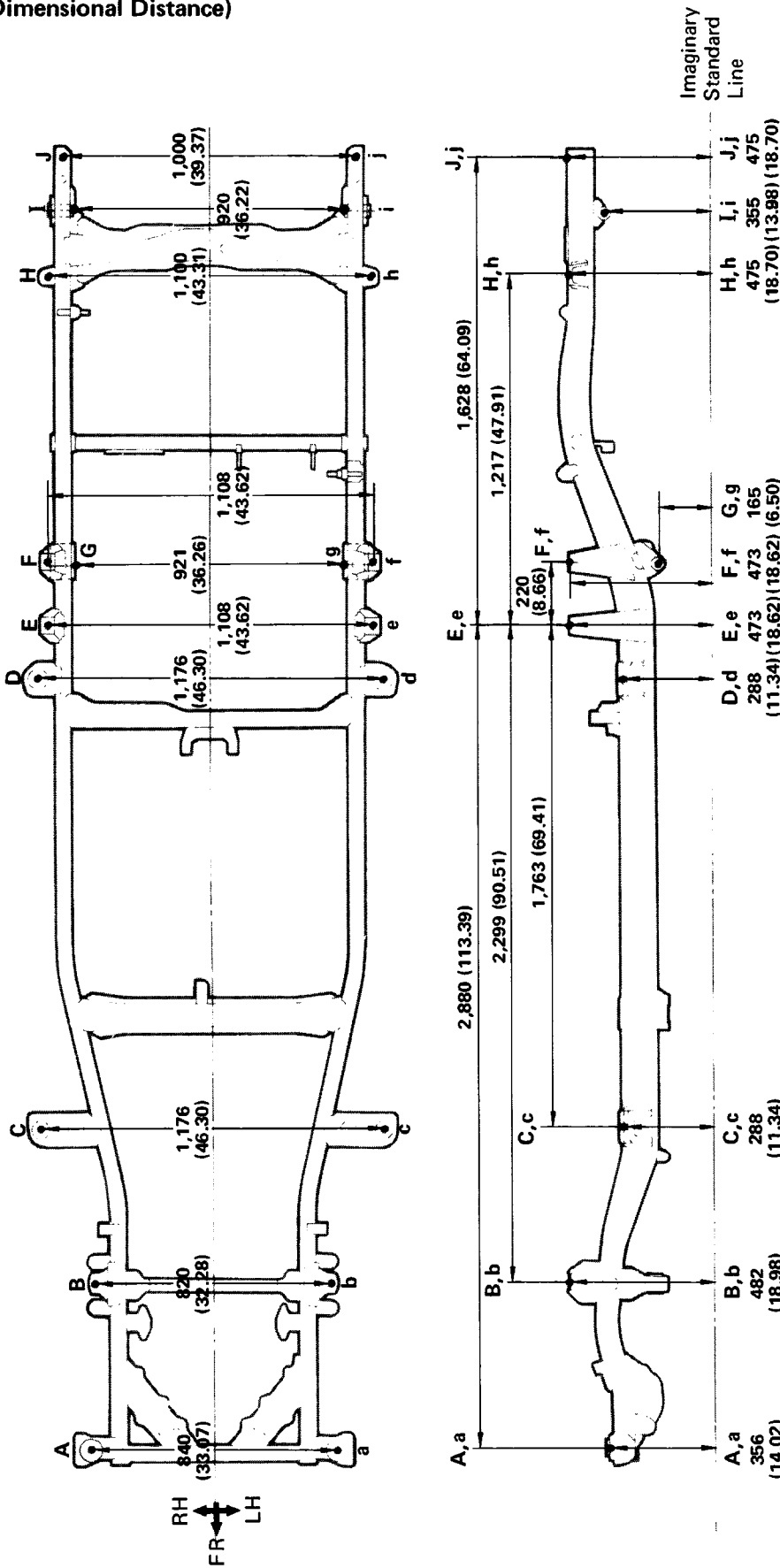

Wheel Base: 3,085 (121.46)

Symbol	Name	Hole dia.	Symbol	Name	Hole dia.
A,a	Cab mounting hole	24 (0.94)	G,g	Rear spring front hanger hole - inner	14.5 (0.571)
B,b	Shock absorber installation hole	16 (0.63)	H,h	Rear body mounting hole	17 (0.67)
C,c	Cab mounting hole	60 (2.36)	I,i	Rear spring rear hanger hole - inner	30.35 (1.1949)
D,d	Cab mounting hole	70 (2.76)	J,j	Rear body mounting hole	18 x 21 (0.71 x 0.83)
E,e	Rear body mounting hole	17 (0.67)			
F,f	Rear body mounting hole	17 (0.67)			

### 4WD Regular Cab: Short Wheel Base Models

(Three-Dimensional Distance)

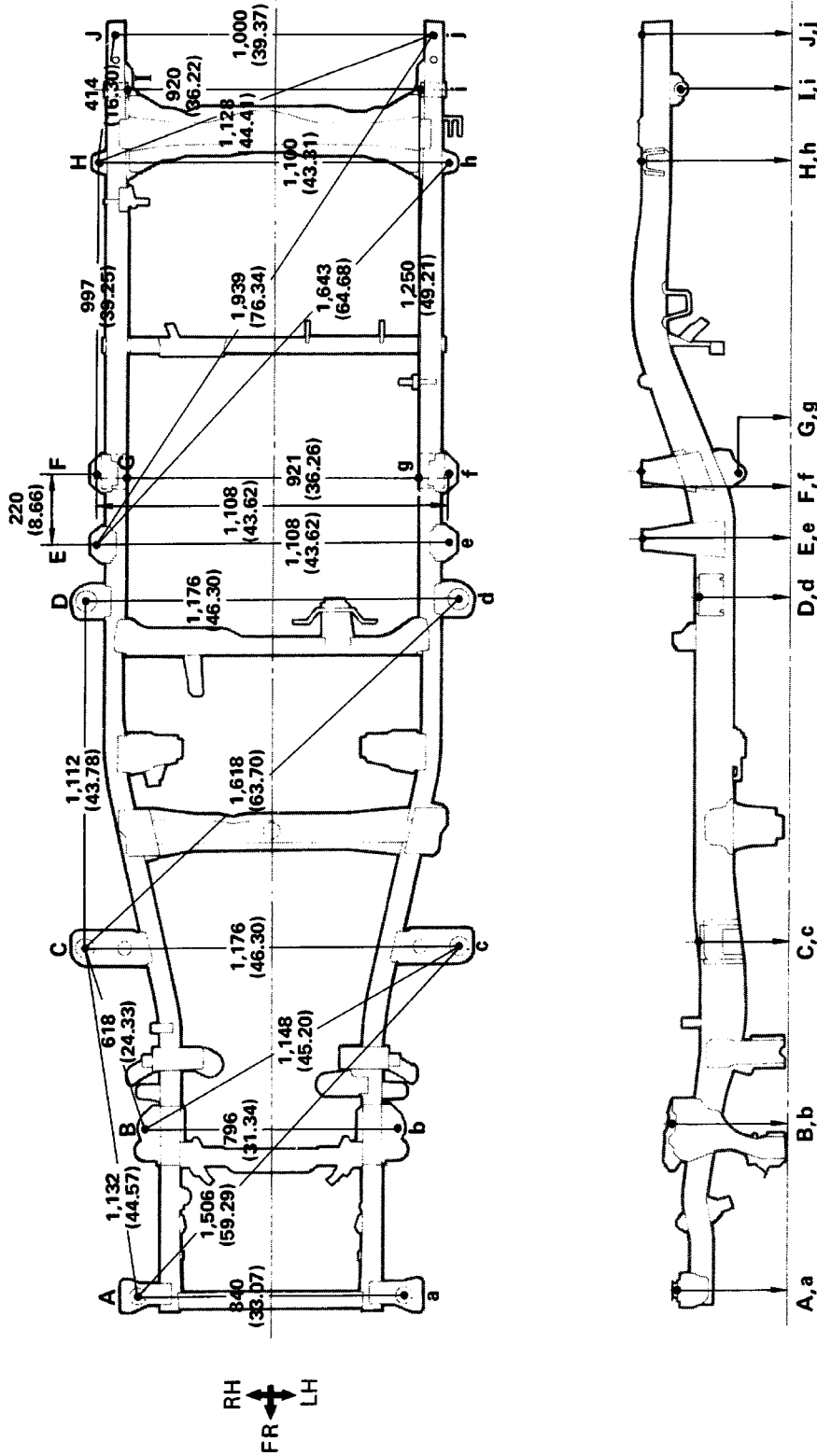

Symbol	Name	Hole dia.	Symbol	Name	Hole dia.
A,a	Cab mounting hole	24 (0.94)	G,g	Rear spring front hanger hole - inner	14.5 (0.571)
B,b	Shock absorber installation hole	16 (0.63)	H,h	Rear body mounting hole	17 (0.67)
C,c	Cab mounting hole	60 (2.36)	I,i	Rear spring rear hanger hole - inner	30.35 (1.1949)
D,d	Cab mounting hole	70 (2.76)	J,j	Rear body mounting hole	18 x 21 (0.71 x 0.83)
E,e	Rear body mounting hole	17 (0.67)			
F,f	Rear body mounting hole	17 (0.67)			

### 4WD Regular Cab: Short Wheel Base Models

(Two-Dimensional Distance)

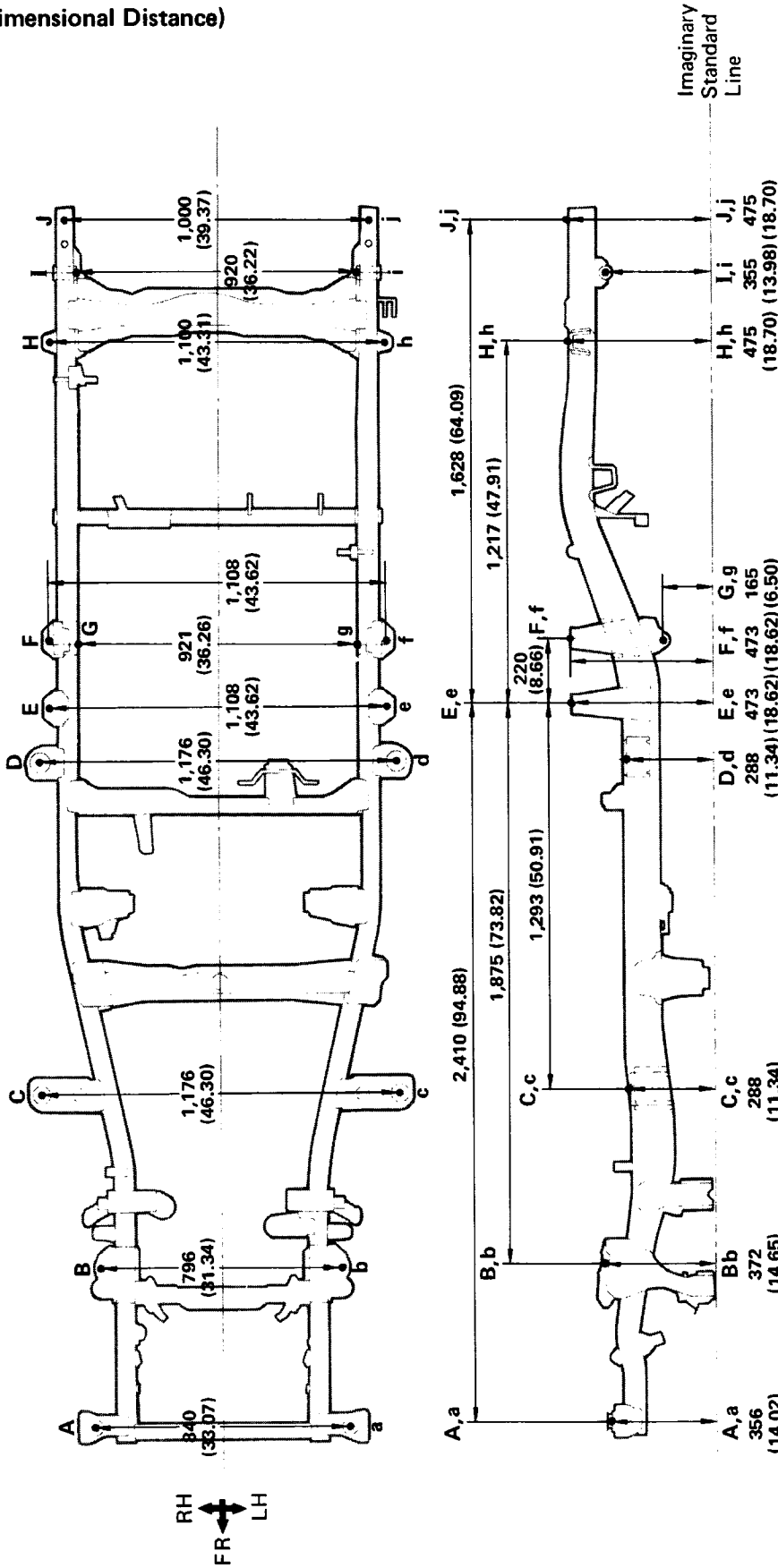

Wheel Base: 2,625 (103.35)

Symbol	Name	Hole dia.	Symbol	Name	Hole dia.
A,a	Cab mounting hole	24 (0.94)	G,g	Rear spring front hanger hole - inner	14.5 (0.571)
B,b	Shock absorber installation hole	16 (0.63)	H,h	Rear body mounting hole	17 (0.67)
C,c	Cab mounting hole	60 (2.36)	I,i	Rear spring rear hanger hole - inner	30.35 (1.1949)
D,d	Cab mounting hole	70 (2.76)	J,j	Rear body mounting hole	18 x 21 (0.71 x 0.83)
E,e	Rear body mounting hole	17 (0.67)			
F,f	Rear body mounting hole	17 (0.67)			

### 4WD Regular Cab: Long Wheel Base Models

(Three-Dimensional Distance)

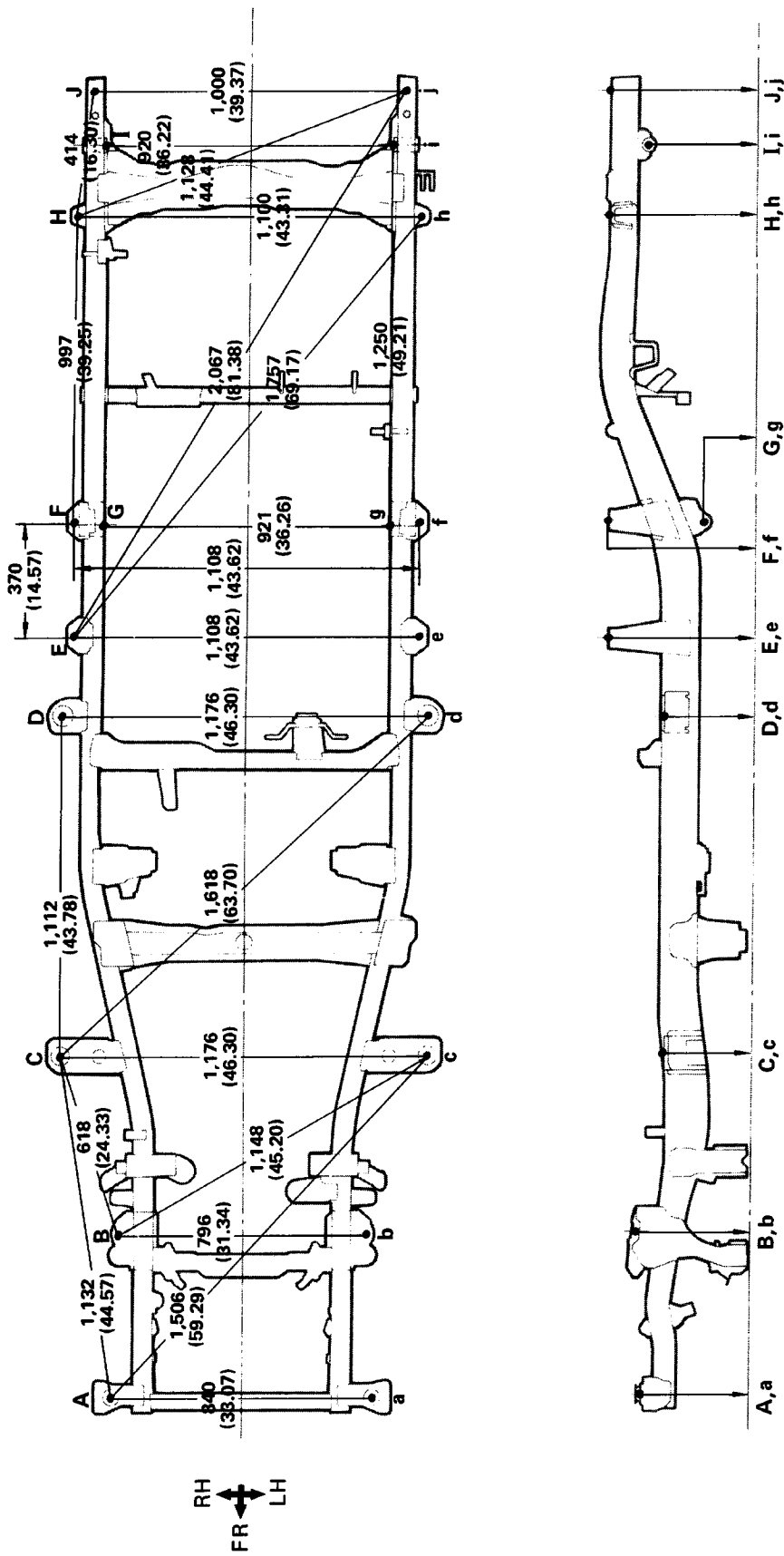

Symbol	Name	Hole dia.	Symbol	Name	Hole dia.
A,a	Cab mounting hole	24 (0.94)	G,g	Rear spring front hanger hole - inner	14.5 (0.571)
B,b	Shock absorber installation hole	16 (0.63)	H,h	Rear body mounting hole	17 (0.67)
C,c	Cab mounting hole	60 (2.36)	I,i	Rear spring rear hanger hole - inner	30.35 (1.1949)
D,d	Cab mounting hole	70 (2.76)	J,j	Rear body mounting hole	18 x 21 (0.71 x 0.83)
E,e	Rear body mounting hole	17 (0.67)			
F,f	Rear body mounting hole	17 (0.67)			

### 4WD Regular Cab: Long Wheel Base Models

(Two-Dimensional Distance)

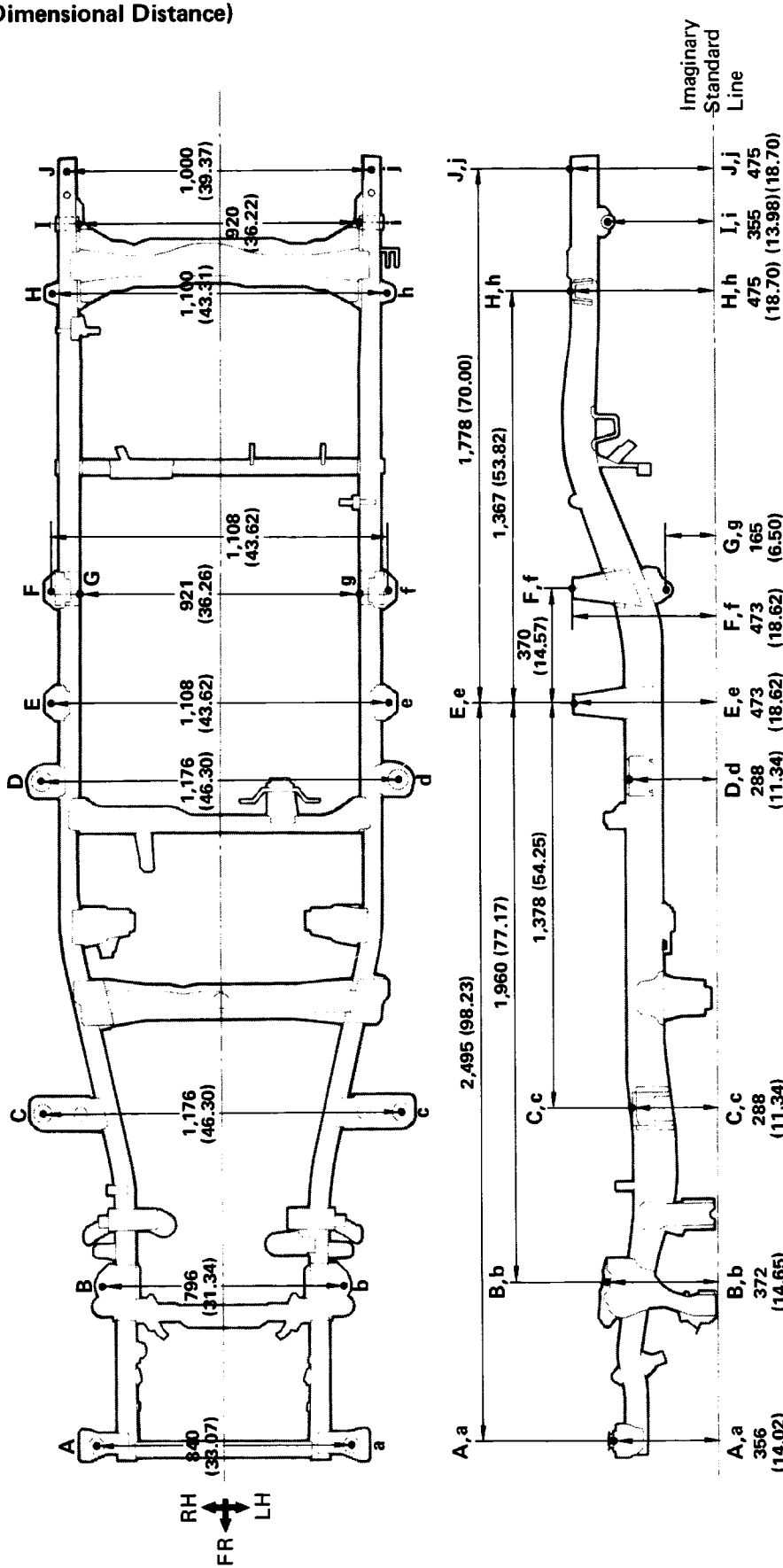

mm (in.)

Symbol	Name	Hole dia.	Symbol	Name	Hole dia.
A,a	Cab mounting hole	24 (0.94)	G,g	Rear spring front hanger hole - inner	14.5 (0.571)
B,b	Shock absorber installation hole	16 (0.63)	H,h	Rear body mounting hole	17 (0.67)
C,c	Cab mounting hole	60 (2.36)	I,i	Rear spring rear hanger hole - inner	30.35 (1.1949)
D,d	Cab mounting hole	70 (2.76)	J,j	Rear body mounting hole	18 x 21 (0.71 x 0.83)
E,e	Rear body mounting hole	17 (0.67)			
F,f	Rear body mounting hole	17 (0.67)			

# 4WD Xtra Cab Models

(Three-Dimensional Distance)

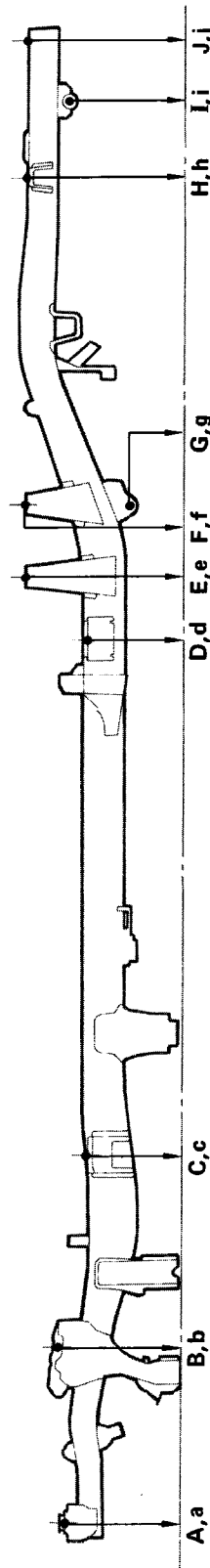
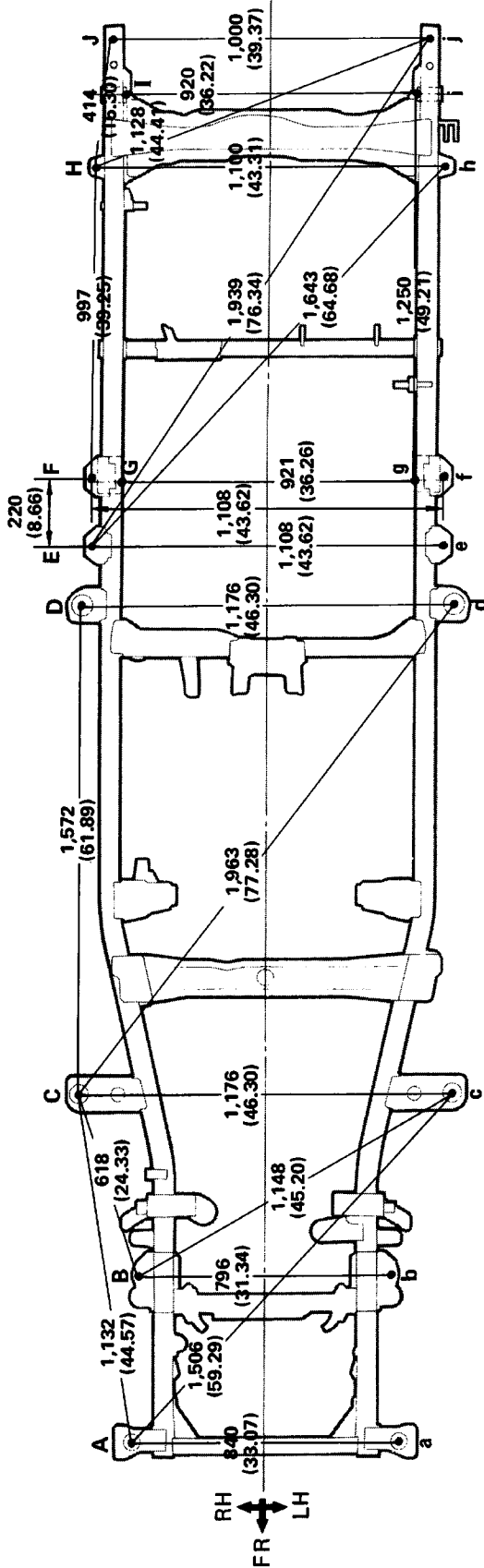

Symbol	Name	Hole dia.	Symbol	Name	Hole dia.
A,a	Cab mounting hole	24 (0.94)	G,g	Rear spring front hanger hole — inner	14.5 (0.571)
B,b	Shock absorber installation hole	16 (0.63)	H,h	Rear body mounting hole	17 (0.67)
C,c	Cab mounting hole	60 (2.36)	I,i	Rear spring rear hanger hole — inner	30.35 (1.1949)
D,d	Cab mounting hole	70 (2.76)	J,j	Rear body mounting hole	18 x 21 (0.71 x 0.83)
E,e	Rear body mounting hole	17 (0.67)			
F,f	Rear body mounting hole	17 (0.67)			

mm (in.)



# 4WD Xtra Cab Models

(Two-Dimensional Distance)

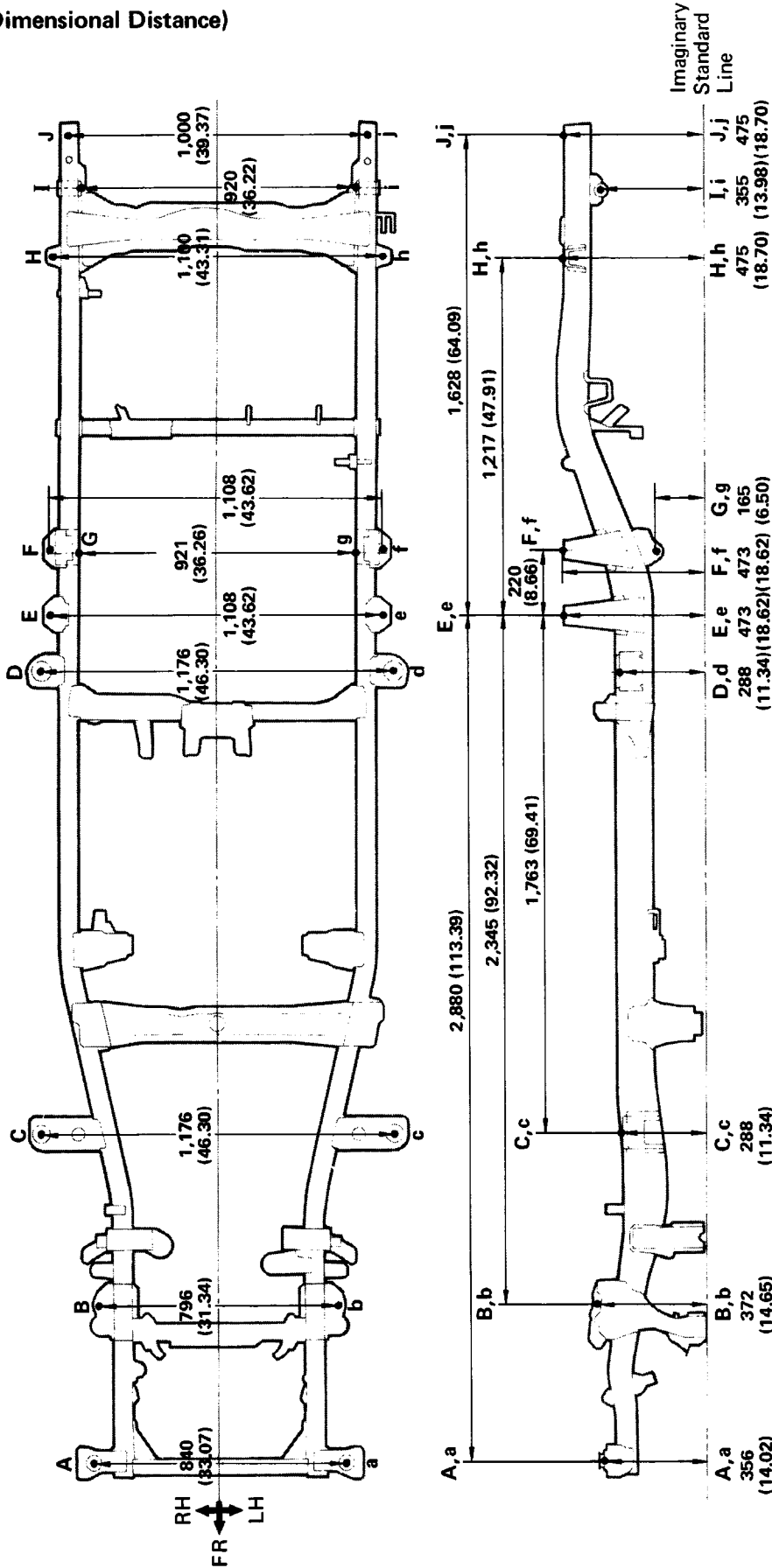

Wheel Base: 3,095 (121.85)

Symbol	Name	Hole dia.	Symbol	Name	Hole dia.
A,a	Cab mounting hole	24 (0.94)	G,g	Rear spring front hanger hole - inner	14.5 (0.571)
B,b	Shock absorber installation hole	16 (0.63)	H,h	Rear body mounting hole	17 (0.67)
C,c	Cab mounting hole	60 (2.36)	I,i	Rear spring rear hanger hole - inner	30.35 (1.1949)
D,d	Cab mounting hole	70 (2.76)	J,j	Rear body mounting hole	18 x 21 (0.71 x 0.83)
E,e	Rear body mounting hole	17 (0.67)			
F,f	Rear body mounting hole	17 (0.67)			